

HD-503 HOSE/GUN CLEANER

Important: Before using this equipment, read all safety precautions and instructions. Keep for future use.

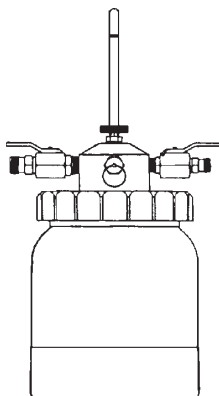

DESCRIPTION



WARNING

Halogenated Hydrocarbon solvents - for example; 1, 1, 1 - Trichloroethane and Methylene Chloride - can chemically react with the aluminum in this hose/gun cleaner and cause an explosion hazard. Read the label or data sheet for the material you intend to spray. Do not use materials containing these solvents with the hose/gun cleaner listed above.

This hose/gun cleaner provides a means of cleaning the inside of material hose, fluid passageways of spray guns and other paint equipment. It is designed to mix solvents and compressed air to pressure flush paint lines and passages quickly and thoroughly, eliminating color contamination and saving time. This results in clean and dry paint passageways using less than 25% of cleaning solvents required in wet flush systems.

SPECIFICATIONS

Fluid Capacity:	2 quarts
Dry Weight:	5 lbs.
Maximum Working Pressure:	50 PSI
Air Inlet Size Ball Valve:	1/4" NPS(M)
Fluid Outlet Size: Ball Valve	3/8" NPS(M)

WETTED PARTS

Wetted parts are aluminum, nickel plated brass, Teflon™ and santoprene gasket.

INSTALLATION



WARNING

Static electricity is produced when using this hose/gun cleaner. Static electricity sparks may be created during the cleaning operation. A spark from static electricity may cause fire or explosion. If the gun or tool attached to the fluid hose line is not grounded, it will build a static charge. To prevent sparks from static electricity, you must ground:

1. The hose/gun cleaner
2. The gun or tool attached to the fluid hose line from the equipment cleaner.
3. The waste container.

To ground equipment:

1. Use air hose containing a static electricity grounding wire.
2. Attach one end of a ground wire to each item listed above.
3. Attach the other end of the wire to a water pipe, metal electrical conduit or any pipe or structural member known to be grounded.

WARNING

Overpressurized equipment and hoses may be damaged or subject to hazardous bursting. Your hose/gun cleaner is designed to have a maximum working pressure (MWP) of 50 psi. Always use hose and accessories designed for this maximum fluid pressure.

WARNING

Air pressure loads that are higher than design loads, or changes to the hose/gun cleaner can cause it to rupture or explode.

A safety valve protects the cleaner from overpressurization. During each use, pull the ring on the safety valve to make sure it operates freely and relieves air pressure. If the valve is stuck, does not operate freely or does not relieve air pressure, it must be replaced. Do not eliminate, make adjustments or substitutions to this valve.

Changes to the hose/gun cleaner will weaken it. Never drill into, weld, or change the hose/gun cleaner in any way.

The maximum working pressure of the cleaner is 50 psi.

OPERATION

When spraying is complete, back flush remaining material in spray gun and hose as follows:

1. Turn off air to material tank and bleed air out of the material tank.
2. Loosen clamps on tank lid. Tip lid so material will run out of fluid tube into material tank.
3. Loosen air cap on gun several turns and hold rag over cap. Pull trigger and force material from gun and hose back into tank.

To clean hose and gun passages:

1. Fill hose/gun cleaner with suitable cleaning solvent (see "Warning" in Column 1 on Halogenated Hydrocarbon solvents). Close lid on cleaner.
2. Connect air hose to 1/4" NPS(M) ball valve on gun/hose cleaner. Close ball valve. Regulate air pressure (must be remotely regulated) to a maximum of 50 psig.
3. Disconnect material hose from material supply tank and connect to 3/8" NPS(M) ball valve on hose/gun cleaner.
4. When ready to clean, open both ball valves on hose/gun cleaner.
5. Turn metering valve on top of hose/gun cleaner to adjust amount of solvent - air ratio. Turn counterclockwise to increase, clockwise to decrease. Fully clockwise shuts off solvent completely. To begin, open counterclockwise at least 2 turns for sufficient solvent for cleaning.
6. Trigger gun with solvent going into spray booth or properly grounded container. Continue spraying until solvent is clear with no traces of paint.
7. Turn metering valve on hose/gun cleaner fully clockwise shutting off solvent flow, while allowing air to continue to flow. Continue until solvent residue is removed.
8. Turn off air at source. Trigger gun to remove residual air pressure. Close both ball valves on hose/gun cleaner.

PREVENTIVE MAINTENANCE

Check lid gasket (7) and needle valve gasket (2) for signs of wear or damage. Replace as needed.

FIGURE 1 - TYPICAL INSTALLATION

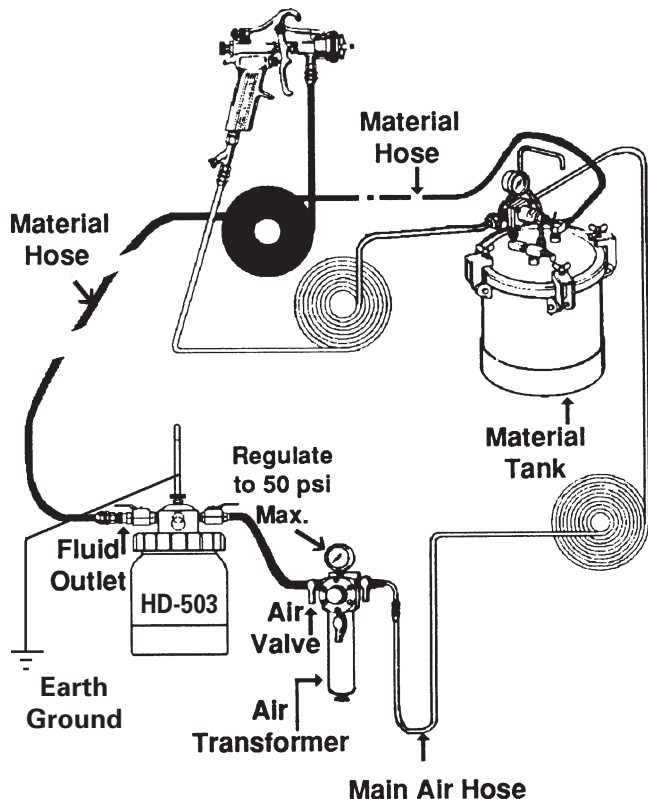
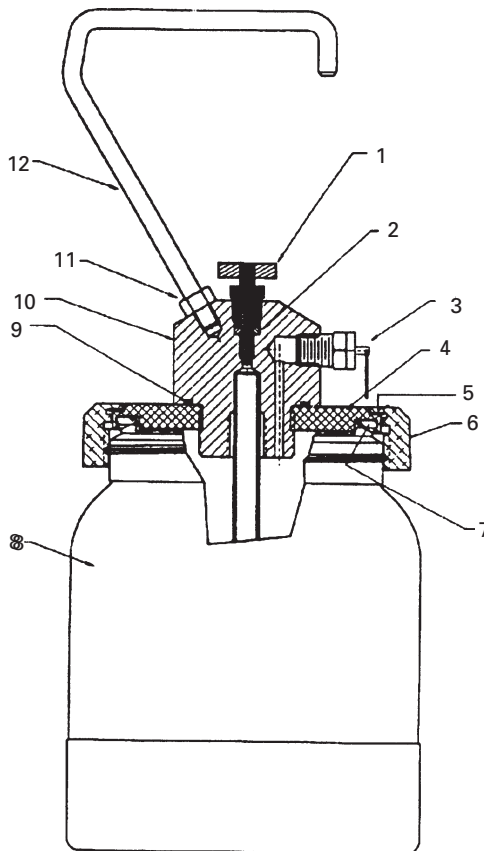

FIGURE 2 - HD-503 HOSE/GUN CLEANER CROSS SECTION VIEW



ACCESSORIES

Air Supply Hose:

H-1921 or 71-20000 Air Hose - with static ground wire braid, 5/16" ID. Also need two 3-piece reusable P-HC-4527 or 72-1317 connectors.

or

H-1958 or 71-21000 Air Hose - with static ground wire braid, 3/8 ID. Also need two 3-piece reusable P-HC-4528 or 72-1325 connectors.

Fluid Delivery Hose:

H-1973-1 or 71-282 Nyliner II fluid hose - 3/8" ID. Also need two 3-piece reusable P-HC-4548 or 72-1328 connectors.

PARTS LIST

Ref. No	Replacement Part Number	Description	Ind. Parts Req.
1	HD-409	Needle Valve Assy.	1
2	HD-39-K2	Needle Valve Gasket (Kit of 2)	1
3	TIA-4355	Safety Valve	1
4	HD-42	Lid	1
5	KB-81-K5	Ring Gasket (Kit of 5)	1
6	KB-64	Retaining Ring	1
7	KB-80-K5	Gasket Kit (Kit of 5)	1
8	KB-422	Cup (2 quart)	1
9	SSG-8184-K2	O-Ring Kit (Kit of 2)	1
10	HD-408	Hub Assembly	1
11	---	Nut (5/16-18)	1
12	KB-74	Handle	1
13	VA-542	Ball Valve, 1/4 NPS (air) (not shown)	1
14	VA-540	Ball Valve, 3/8 NPS (fluid) (not shown)	1

• Purchase locally.

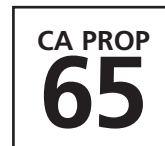

PROP 65 WARNING

WARNING: This product contains chemicals known to the State of California to cause cancer and birth defects or other reproductive harm.

IT IS THE RESPONSIBILITY OF THE EMPLOYER TO PROVIDE THIS INFORMATION TO THE OPERATOR OF THE EQUIPMENT.

FOR FURTHER SAFETY INFORMATION REGARDING BINKS AND DEVILBISS EQUIPMENT, SEE THE GENERAL EQUIPMENT SAFETY BOOKLET (77-5300).

WARRANTY

This product is covered by DeVilbiss' 1 Year Limited Warranty.

DeVilbiss Sales and Service: www.devilbiss.com

DeVilbiss

DeVilbiss has authorized distributors throughout the world. For technical assistance or the distributor nearest you, see listing below.

U.S.A./Canada Customer Service Office:

195 Internationale Blvd., Glendale Heights, IL 60139
Toll-Free Telephone: 1-800-992-4657 (U.S.A. and Canada only)
Toll-Free Fax: 1-888-246-5732

DeVilbiss Automotive Refinishing

DeVilbiss has authorized distributors throughout the world. For equipment, parts and service, check the Yellow Pages under "Automotive Body Shop Equipment and Supplies." For technical assistance, see listing below.

U.S.A./Canada Customer Service Office:

11360 S. Airfield Road, Swanton, OH 43558
Toll-Free Telephone: 1-800-445-3988 (U.S.A. and Canada only)
Toll-Free Fax: 1-800-445-6643

